

# Technical Description

## ■ Overview

Proximity sensor is the non contact detector (sensor) which detects the sensing target when it comes close, not same as the micro switch or the limit switch using the mechanical contact sensing method.

## ■ Principle And Feature

### ◎ Inductive proximity sensor

#### ● Principle

When the object (metallic) approaches the high-frequency magnetic field which is produced at the detection coil, induced currents flow in the metal, causing thermal loss and resulting in the reduction or stopping of oscillations. This change in state is detected by an oscillation state sensing circuit which then operates the output circuit.

#### ● Principles of operation

When the proximity sensor is on, the oscillation of the current within 60ms will be increased to certain frequency, and electric field is formed. After that, if the object approaches, the induced current surrounding the sensing object will be increased, and the oscillation of the current will be decreased. When the object is detected completely, the current will be close to 0V. This very little oscillation of the current will be amplified, and will operate the output section.

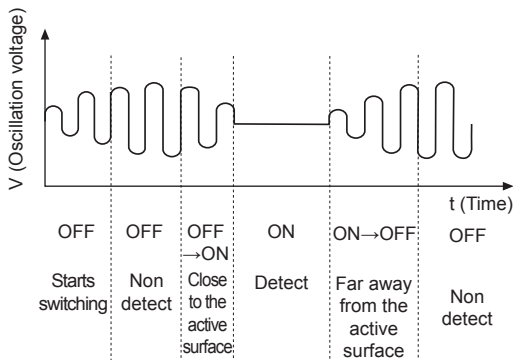

#### ● Configuration

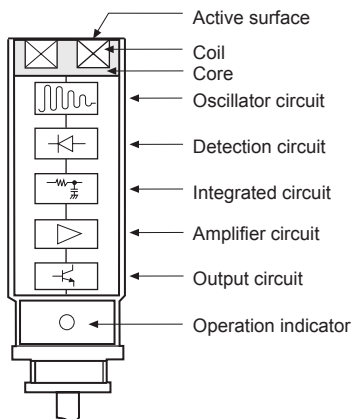

### ◎ Capacitive proximity sensor

#### ● Principle

As shown below figure, when + current is applied on the pole plate, + charge will be on the pole plate, - charge will be on the ground, and the electric field will be occurred between the pole plate and the ground. When the object approaches to the pole plate, the charges in the object move by the electrostatic induction. - charge will move to the pole plate side, and + charge will move to the other side. This state is called polarization. The object is detected by the strength of the polarization which is strong when the object moves to the pole plate side, and is weak when the object moves far away from the pole plate.

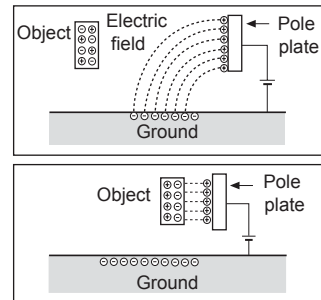

#### ● Principle of operation

Capacitive proximity sensor works contrary method to the inductive proximity sensor. When the sensor power is on, the oscillation of the current is close to 0V. When the object approaches to the sensor, the capacitance will be increased and the oscillation of the current is increased. This output section will be operated by increasing the oscillation.

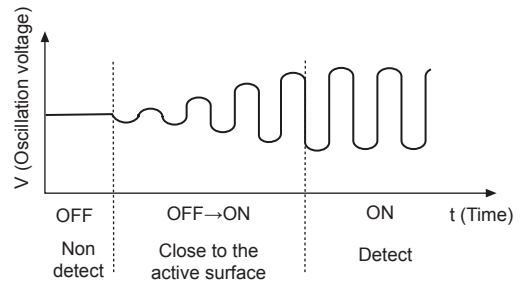

#### ● Configuration

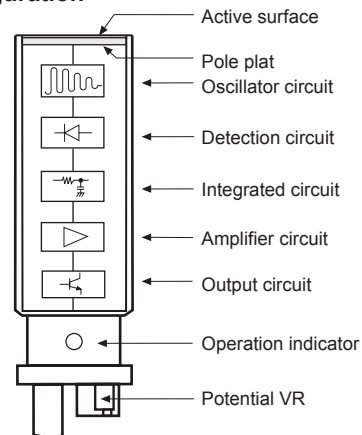

## ■ Glossary

### ◎ Standard sensing target

It is the standard of shape, size, and material for each model to measure the standard performance.

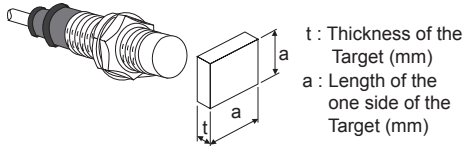

### ◎ Sensing distance (Sn)

It is the distance between the active surface and the surface of the sensing target, when the output works by approaching the sensing target to the active surface. The specification of sensing distance (Sn) for each series is measured by standard sensing target.

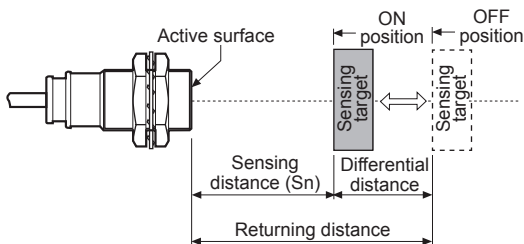

### ◎ Differential distance (Hysteresis)

The hysteresis is the difference between the operation distance, when the sensor first operates with the standard sensing target approaching from the active surface direction, and the returning distance, when the sensor first stops operating with the standard sensing target receding. This hysteresis prevents chattering of the output due to vibration, etc., of the sensing target.

### ◎ Setting distance

It is the sensing range for which the sensor can stably detect the standard sensing target even if there is an ambient temperature drift and/or supply voltage fluctuation. Normally, it is 70% of the maximum operation distance.

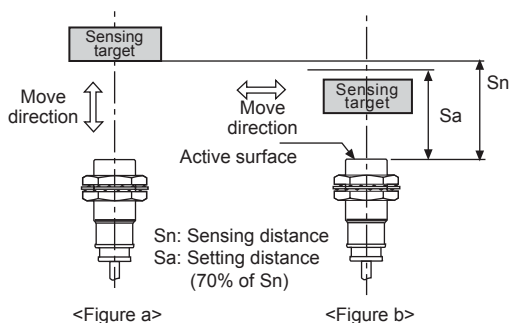

- After verifying the sensing distance like <Figure a>, please move the target within the stable sensing range like <Figure b>.

### ◎ Response frequency

The number of times per second at which sensing can be done without malfunction, when approach the standard sensing target to the sensor. It shows Hz.

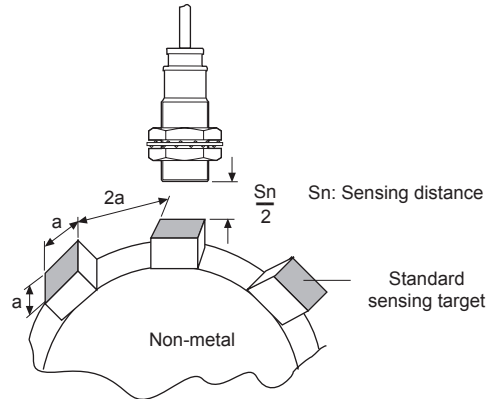

< Response frequency measurement method >

$$\text{Response frequency (f)} = \frac{1}{T} \quad [\text{Hz}]$$

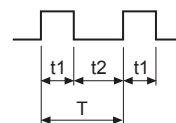

### ◎ Relative dielectric constant

It is the ratio of between the dielectric constant of the material ( $\epsilon$ ) and the dielectric constant of vacuum ( $\epsilon_0$ ).

$$\epsilon_s = \frac{\epsilon}{\epsilon_0}$$

As the relative dielectric constant is big, the sensing distance is long. And each material has its own value of the relative dielectric constant. The value of the relative dielectric constant for solid is bigger than liquid. There are the relative dielectric constants for typical materials.

Air	1	Polystyrene	1.2
Paper	2.3	PVC	3
Wood	6 to 8	Glass	5
Alcohol	25.8	Water	80

### ◎ Capacitance

It is the amount of the accumulated charge (Q), when apply voltage at the insulated conductors. As the accumulated charge (Q) is big, the sensing distance becomes long.

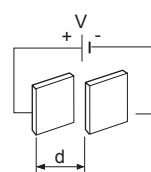

$$\text{Capacitance (C)} = \frac{Q}{V} = \frac{\epsilon A}{d}$$

- A : The area of the pole plate
- d : The distance between two pole plate
- Q : Charge
- $\epsilon$  : Dielectric constant

As shown above formula, the capacitance (C) will be increased as the amount of charge (Q) is increased. There are the methods to increase the capacitance, increase the area of the pole plate, use the material that the relative dielectric constant is big or narrow the distance between two pole plates.

(A) Photoelectric Sensors

(B) Fiber Optic Sensors

(C) Door/Area Sensors

(D) Proximity Sensors

(E) Pressure Sensors

(F) Rotary Encoders

(G) Connectors/ Sockets

(H) Temperature Controllers

(I) SSRs / Power Controllers

(J) Counters

(K) Timers

(L) Panel Meters

(M) Tacho / Speed / Pulse Meters

(N) Display Units

(O) Sensor Controllers

(P) Switching Mode Power Supplies

(Q) Stepper Motors & Drivers & Controllers

(R) Graphic/ Logic Panels

(S) Field Network Devices

(T) Software

# Technical Description

## Mount Sensor

### Flush type mounting (shield type)

The most area of the proximity sensor is surrounded by metal except the active surface to prevent the effect of the approaching metal from side. Even though the sensing distance is shorter than non-flush type, the active surface of the sensor can be mounted at the same level of the metal enclosure like below figure.

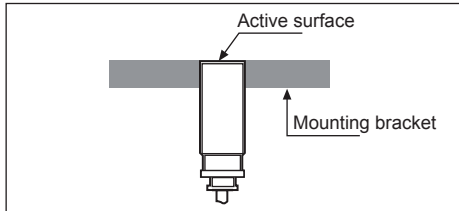

### Non-flush type mounting (non shield type)

The sensor is affected easily by approaching metal from side because the side of the active surface was not shield by metal. The sensing distance is longer than the flush type, but when mount the sensor, please mount on the concave side, and keep the distance three times longer than the diameter of the sensor like below figure.

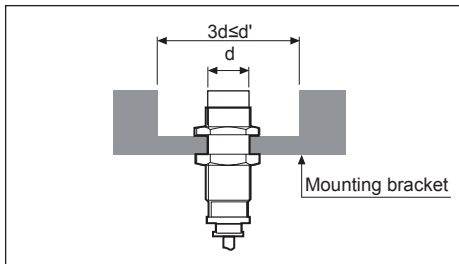

### Parallel mounting

When several proximity sensors are mounted close together, there is the effect of mutual interference. Therefore please keep the distance which is two times longer than the diameter of the sensor for flush type, and three times longer than the diameter of the sensor for the non-flush type.

(Non-flush type)

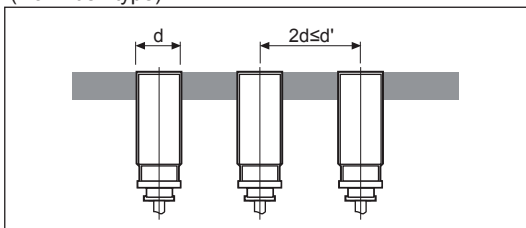

(Flush type)

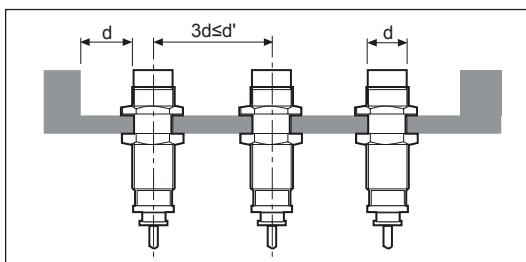

### Face to face mounting

When proximity sensors are mounted in face to face, malfunction of sensor may be caused due to mutual interference. Therefore, please keep the distance which is six times longer than the sensing distance.

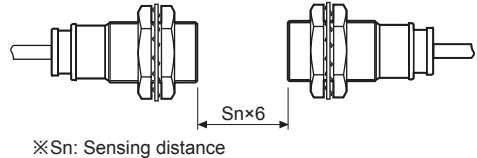

### Tightly mounting

When proximity sensors are mounted tightly, malfunction of sensor may be caused due to mutual interference. Therefore, please use differential frequency for the application like below picture. Differential frequency type is only for PSN17 series.

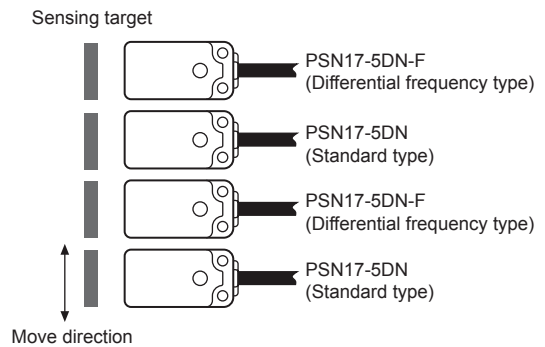

## Connection For DC Type

### DC 2-wire type

#### Load connection

If DC 2-wire type is connected without load, the inner device of DC 2-wire type can get damage. Please connect the load before apply power. The load can be connected any power line.

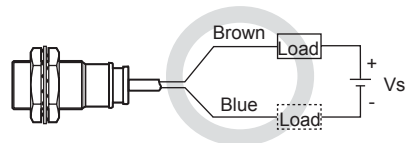
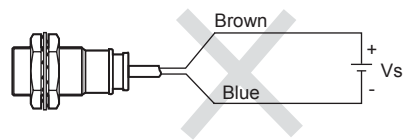

## ● To connect DC 2-wire type sensor with PLC (Programmable Logic Controller)

DC 2-wire type of proximity sensor can be connected with PLC when input specification of PLC and proximity sensor specification comply with the conditions shown below.

1) When ON voltage of PLC and residual voltage of sensor meet following formula.

$$V_{on} \leq V_S - V_R$$

2) When OFF voltage of PLC and a leakage current of sensor meet following formula.

$$I_{off} \geq I_L$$

3) When ON current of PLC and control output current of sensor meet following formula.

$$I_{out}(\min) \leq I_{on}$$

[Note]

- V<sub>on</sub> : ON voltage of PLC
- V<sub>S</sub> : Source voltage
- V<sub>R</sub> : Residual voltage of proximity sensor
- I<sub>off</sub> : OFF current of PLC
- I<sub>L</sub> : A leakage current of proximity sensor
- I<sub>out</sub> (min) : The min. value of proximity sensor's control output
- I<sub>on</sub> : ON current of PLC

E.g.) PLC input specification - ON voltage: over 15VDC

ON current: over 4.3mA

OFF current: under 1.5mA

Proximity sensor - PRT18-5DO, source voltage is 24VDC

1)  $V_{on} (15V) \leq V_S (24V) - V_R (3.5V) = 20.5V$  : OK

2)  $I_{off} (1.5mA) \geq I_L (0.6mA)$  : OK

3)  $I_{out}(\min) (2mA) \leq I_{on} (4.3mA)$  : OK

## ● Connect DC 2-wire type sensor with PLC (Programmable Logic Controller)

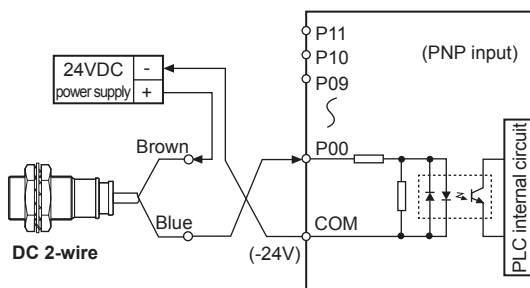

< PLC's Common terminal is "-24V" >

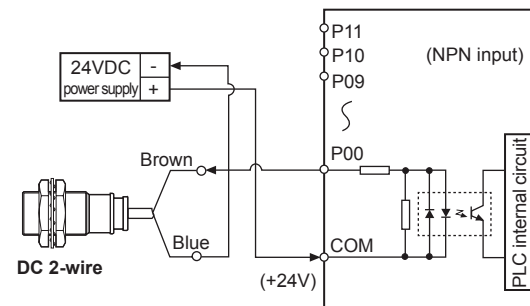

< PLC's Common terminal is "+24V" >

## ● AND (series) connection

When it is connected in series, all proximity sensors have to be in working to make loads operated. The residual voltage which is related with the number of the sensor should not influence both operating voltage of proximity sensors and driving voltage of a load, and which condition should be considered to choose how many sensors to be connected in series.

To connect sensors in series, choose the number of proximity sensors within the amount that meets formula below.

$$V_S - (n \times V_R) \geq \text{Operating voltage of load.}$$

$$\left[ \begin{array}{l} V_S : \text{Source voltage} \quad V_R : \text{Residual voltage} \\ n : \text{The number of connected sensors} \end{array} \right]$$

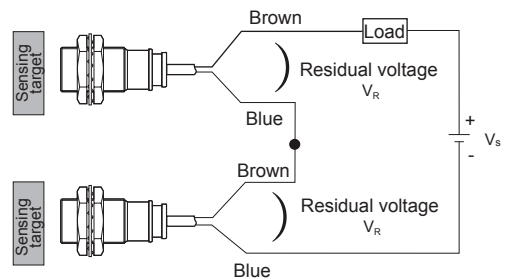

## ● OR (parallel) connection

When it is connected in parallel, it works even only one sensor is on operation. A little current flows as a leakage current because proximity sensor operates internal circuit even when it is OFF. Because a number of sensors connected in parallel increase the amount of leakage current, load could run when proximity sensor is in OFF status.

Thus, the leakage current which is related with the number of the sensor should not influence the returning current of load, and which condition should be considered to choose how many sensors to be connected in parallel.

To connect several sensors in parallel, choose the number of proximity sensors within the amount that meets the formula below.

$$n \times I_L \leq \text{The returning current of load}$$

$$\left[ \begin{array}{l} n : \text{The number of connected sensors} \\ I_L : \text{The leakage current of sensor} \end{array} \right]$$

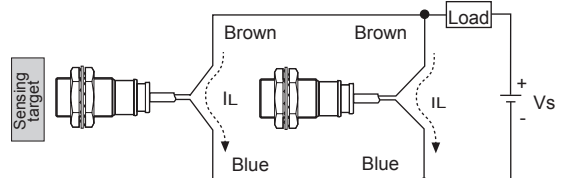

E.g.) When load is relay (24VDC), and connecting PRT18-5DO in parallel,

• The returning current of load : Max. 3.7mA

• The leakage current of PRT18-5DO : Max. 0.6mA

Six sensors can be connected in parallel in Max.

(A) Photoelectric Sensors

(B) Fiber Optic Sensors

(C) Door/Area Sensors

(D) Proximity Sensors

(E) Pressure Sensors

(F) Rotary Encoders

(G) Connectors/ Sockets

(H) Temperature Controllers

(I) SSRs / Power Controllers

(J) Counters

(K) Timers

(L) Panel Meters

(M) Tacho / Speed / Pulse Meters

(N) Display Units

(O) Sensor Controllers

(P) Switching Mode Power Supplies

(Q) Stepper Motors & Drivers & Controllers

(R) Graphic/ Logic Panels

(S) Field Network Devices

(T) Software

# Technical Description

## ◎ DC 3-wire type

### ● Load connection

In DC 3-wire type of proximity sensor, there are two types of output, NPN and PNP, and they can either open or close power relay, solenoid, electric counter, PLC, etc.

※In case of using inductive load (relay, motor, magnet, etc.), connect surge absorber diode in parallel with load. Use diode, of which withstand voltage is threefold over power supply.)

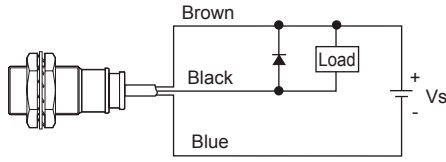

(A circuit using NPN type sensor)

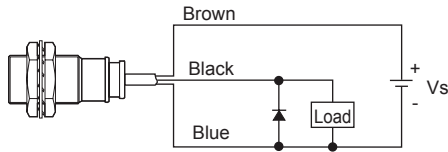

(A circuit using PNP type sensor)

### ● Connection with PLC (Programmable Logic Controller)

When connecting DC 3-wire type of proximity sensor with PLC, applicable sensor is chosen differently depend on common terminal status.

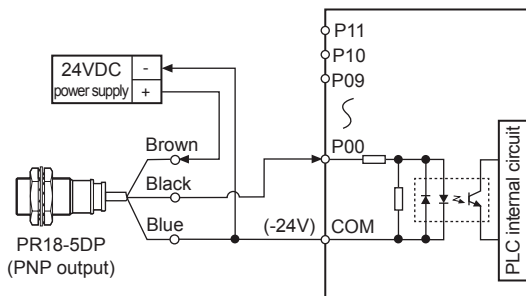

< PLC's Common terminal is "-24V" >

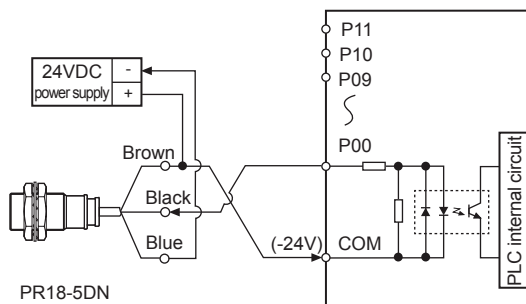

< PLC's Common terminal is "+24V" >

### ● AND (series) connection

When it is connected in series, all proximity sensors have to be in working to make loads operated. The residual voltage which is related with the number of the sensor should not influence both operating voltage of proximity sensors and driving voltage of a load, and which condition should be considered to choose how many sensors to be connected in series. PNP output type sensor and NPN output type sensor cannot be used in a same circuit.

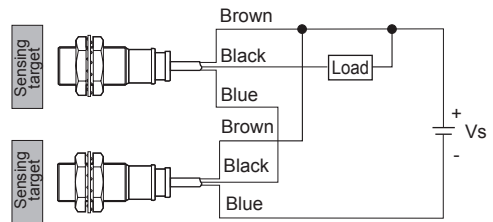

(Series connection of NPN output type sensors)

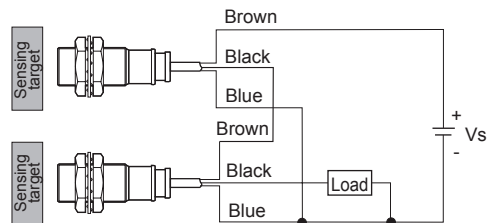

(Series connection of PNP output type sensors)

### ● OR (parallel) connection

When it is connected in parallel, it works even one sensor is on operation.

The leakage current which is related with the number of the sensor should not influence the returning current of load, and which condition should be considered to choose how many sensors to be connected in parallel. PNP output type sensor and NPN output type sensor cannot be used in a same circuit.

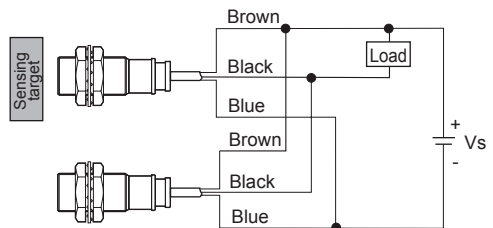

(Parallel connection of NPN output type sensors)

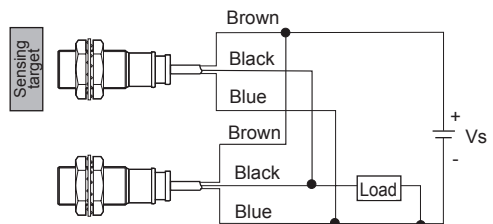

(Parallel connection of PNP output type sensors)

## ■ How To Connect Ac Type Proximity Sensor

### ◎ Load connection

When using AC 2-wire type sensor, load have to be wired in circuit, otherwise internal element gets burn when power is supplied. Load could be connected any side of power wire.

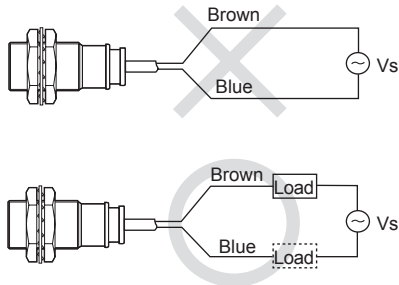

### ● When operating current of load is not enough

When operating current of load is under 5mA, use bleeder resistance so that current flowing through load can be increased to over 5mA.

Use the formula below to calculate the value of bleeder resistance and allowable current.

$$R \leq \frac{V_s}{I} (\Omega) \quad P > \frac{V_s^2}{R} (W)$$

\* I : Operating current of load  
P: Allowable voltage  
R: Bleeder resistance

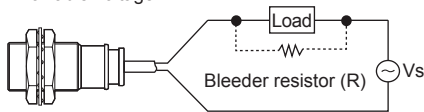

Use load of over 20kΩ 3W for 110VAC power, over 39kΩ 10W for 220VAC.

※When having thermogenic problem, use load that has larger value of watt.

### ◎ AND (series) connection

In principle AC type of proximity sensor cannot be used in series connection. To use it in series connection, put relay or bleeder resistance in circuit.

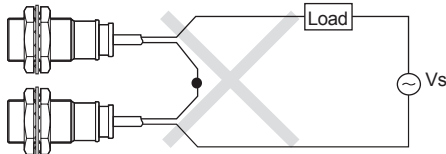

(Figure 1) The wrong way of series connection

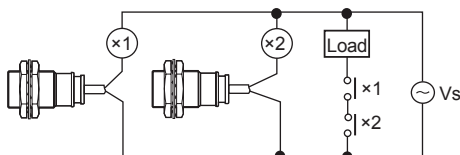

(Figure 2) The right way of series connection

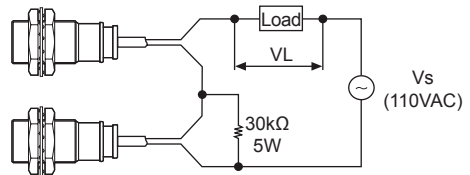

(Figure 3) Bleeder resistance connection method

※Bleeder resistance is not needed when power voltage is 220VAC.

### ● Load power voltage check

When connecting in series, operating voltage,  $V_L$ , is calculated as subtraction of power source voltage and residual voltage of proximity sensor. Thus, it would follow a formula ;  $V_L = \text{power source voltage} - (\text{residual voltage of proximity sensor} \times \text{the number of sensor})$

E.g.)  $V_s = 110\text{VAC}$ , operating voltage of load  
 $V_L = 110 - (10 \times 2) = 90\text{V}$ , so load that works with 90VAC must be used.

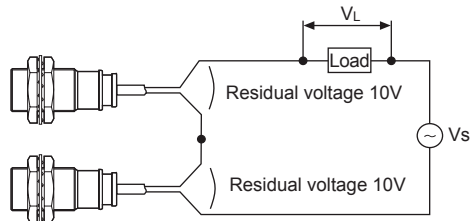

### ◎ OR (parallel) connection

More than two sensors cannot be connected in a same circuit to operate load. Even though parallel connection is possible when those sensors are not being operated at a same time, because leaking current is increased by n times, returning faulty of load can occur. (n: the number of connected sensors)

Thus, connect relay in parallel so that load can work properly.

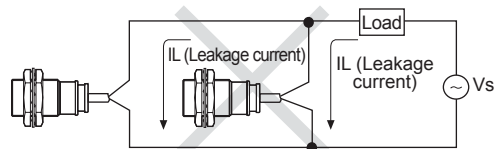

(Figure 4) The wrong way of parallel connection

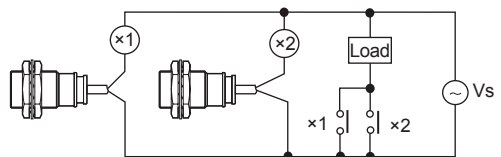

(Figure 5) The right way of parallel connection

(A) Photoelectric Sensors

(B) Fiber Optic Sensors

(C) Door/Area Sensors

(D) Proximity Sensors

(E) Pressure Sensors

(F) Rotary Encoders

(G) Connectors/ Sockets

(H) Temperature Controllers

(I) SSRs / Power Controllers

(J) Counters

(K) Timers

(L) Panel Meters

(M) Tacho / Speed / Pulse Meters

(N) Display Units

(O) Sensor Controllers

(P) Switching Mode Power Supplies

(Q) Stepper Motors & Drivers & Controllers

(R) Graphic/ Logic Panels

(S) Field Network Devices

(T) Software